

PAGE: 1 of 11
ISSUE: A 00
DATE: 07/16/15

DOCUMENT TITLE

**9.0kg ABE TYPE
STORED PRESSURE DRY POWDER
PORTABLE FIRE EXTINGUISHER**

MODEL: R9.0ABE

0	07/16/15	ISSUED FOR USE AS ISSUE 'A'	WJJ	LRL	LHG
REV	DATE	REVISION DESCRIPTION	BY	CHK	APP

COVER PAGE/REVISION STATUS

RUIHUA RESERVE THE RIGHT TO UPDATE AND CHANGE THIS TECHNICAL DATA AT ANY TIME WITHOUT NOTICE

CONTENTS

1. PURPOSE
2. GENERAL DESCRIPTION AND OPERATION
3. SPECIFICATIONS
4. MATERIALS AND CONSTRUCTION
5. EXTINGUISHANT
6. FINISH
7. QUALITY ASSURANCE
8. APPROVALS
9. INSTALLATION
10. SERVICING AND DRAWINGS

PRODUCT: 9.0kg ABE DRY POWDER FIRE EXTINGUISHER

PAGE: 3 of 11

MODEL No's: R9.0ABE

ISSUE: A 00

DATE: 07/16/15

1. PURPOSE

This dry powder type fire extinguisher has been designed for easy operation by one person.

Clear instructions are fixed to the extinguisher to enable even an untrained person to quickly bring the extinguisher into operation.

It has been developed for use on the following types of fires.

CLASS 'A' - Fires Fires involving wood, paper, textiles and plastics.

CLASS 'B' - Fires Fires involving flammable and combustible liquids, petrol, oil and grease etc.

CLASS 'E' - Fires Fires involving energised electrical equipment.

Note: It is not suitable for fires involving combustible metals such as magnesium, zirconium etc. or for fires involving cooking oils and fats.

2. GENERAL DESCRIPTION AND OPERATION

The extinguishing medium used in this fire extinguisher is a monoammonium phosphate based powder.

This extinguisher is of the stored pressure type. The dry powder is stored in a cylinder, pressurised with dry nitrogen and a small amount of helium to 1500 kPa. Discharge is by operation of the squeeze grip lever.

When the squeeze grip lever is depressed, the dry powder flows up through the siphon tube and valve and out through the hose nozzle for direction onto the fire. The squeeze grip operation permits 'on and off' control, enabling the operator to conserve powder and move from point to point when fighting a fire.

OPERATION IS SIMPLE

Instructions:

1. Hold upright.
 Pull out the safety pin.
2. Stand back 2 metres.
 Aim nozzle at base of fire.
3. Squeeze handles.
 Sweep under the flames.

PRODUCT: 9.0kg ABE DRY POWDER FIRE EXTINGUISHER

PAGE: 4 of 11

MODEL No's: R9.0ABE

ISSUE: A 00

DATE: 07/16/15

The valve will re-seal when pressure is removed from the operating lever, thus providing for intermittent discharge when required.

These extinguishers must be used in an upright position to ensure full discharge of the contents.

Note: The extinguisher must be recharged immediately after any use.

3. SPECIFICATIONS

Extinguisher Capacity	9.0kg
Model Number	R9.0ABE
Gross Mass – Charged	13.6 kg
Diameter of body	182 mm
Height of overall	562 mm
Ratings to AS/NZS1850	6A:80B:E
Operating Pressure @ 23 C	1500 kPa
Periodic Test Pressure	2.25 MPa
Discharge time (approx)	20 to 23 secs
Packaging carton sizes: Height	590 mm
Width	200mm
Depth	195 mm

Each extinguisher is individually packed, complete with all mounting fittings in a rigid cardboard carton suitable for transport.

4. MATERIALS AND CONSTRUCTION

4.1 CYLINDER

The cylinder body components are manufactured from carbon steel. The cylinder body is of welded construction.

After fabrication all cylinders are hydrostatically pressure tested to 2500kPa for 30 seconds minimum. Cylinders are then dried and all external surfaces phosphated. The external surfaces are then finish polyester powder coated red approximating signal red.

4.2 VALVE ASSEMBLY

Consists of the valve body, carrying handle, operating lever, actuating valve stem assembly, spring, siphon tube assembly, pressure gauge and safety pin.

PRODUCT: 9.0kg ABE DRY POWDER FIRE EXTINGUISHER

PAGE: 5 of 11

MODEL No's: R9.0ABE

ISSUE: A 00

DATE: 07/16/15

4.2.1. Valve Body

The valve body is machined from a brass forging and nickel plated.

4.2.2. Handle and Operating Lever

The handle and operate lever are made from stainless steel and secured to the valve assembly with a stainless steel pin.

4.2.3. Valve Stem Assembly and Spring

The valve stem assembly consists of a brass check stem and rubber 'O' ring and seat seals.

The spring is stainless steel conical coiled and locates on the underside of the nut.

4.2.4. Siphon Tube Assembly

Consists of a siphon tube and siphon tube nut. The siphon tube material is made out of PVC tube, threaded one end for attaching the tube nut, which is made from nylon.

The assembly screws into the bottom of the valve body by means of the threaded tube nut, which also captivates the valve spring.

4.2.5. Pressure Gauge

The gauge has a stainless steel case and a brass stem, which screws directly into the valve body. It indicates the nitrogen gas pressure within the extinguisher. Its colour printed face shows the normal operating pressure of 1500kPa.

The operable pressure range is shown by a green coloured sector.

4.2.6. Safety Pin

The safety pin interlocks the operating lever to the carrying handle and prevents accidental discharge of the extinguisher when not in use. This pull out type pin must be withdrawn from the operating lever before the extinguisher can be operated.

The pin is made from stainless steel.

A pull tight anti-tamper seal straps through the safety pin and around the valve handles.

4.3. Nozzle and Hose Assembly

The hose assembly consists of a textile reinforced PVC rubber hose, a nickel plated iron inlet adaptor and an outlet nozzle made from acetal copolymer.

These fittings are secured to the hose by means of crimped iron ferrules.

The hose assembly is secured to the valve outlet by its threaded inlet adaptor.

4.4. LABEL

The label indicates the extinguisher contents, fire ratings, and the classes of fire for which it is approved. The label also features (both written and pictorial) simple operating instructions and states the standard and licence number to which the extinguisher is produced. In addition to the main label a white band at the top of the extinguisher cylinder identifies the extinguisher as a powder type.

PRODUCT: 9.0kg ABE DRY POWDER FIRE EXTINGUISHER

PAGE: 6 of 11

MODEL No's: R9.0ABE

ISSUE: A 00

DATE: 07/16/15

4.5 MOUNTINGS

Models are supplied with a carbon steel wall hook for attachment to a wall surface with two zinc plated steel fixing screws. The extinguisher hangs on the bracket through a hole in the valve hanging lug.

5. EXTINGUISHANT

The dry powder used in this extinguisher is a 70% monoammonium phosphate based powder containing special agents to render its free-flowing capabilities. It is green in colour and as a fire fighting agent it produces no toxic effects.

Trade name Presto Super ABE powder.

6. FINISH

Extinguisher Body: Finish polyester powder coated red to approximate colour R13 of AS2700.

Valve Body: Brass, Nickel Plated.

Handle and Lever: Stainless Steel. Natural Finish

7. QUALITY ASSURANCE

The company is a registered Quality Assured Supplier operating to ISO9001 Quality Standard. All components are manufactured to conform to specific design specifications and are subject to strict quality control at every stage of manufacture.

8. APPROVALS

Approved to Australian Standard AS/NZS 1841.5 License No. 102557 by Global-Mark.

9. INSTALLATION

For Australia, install as per Australian Standard AS2444: Portable fire extinguishers and fire blankets selection and location.

For New Zealand, install as per New Zealand Standard NZS4503: The distribution, installation and maintenance of hand operated fire fighting equipment for use in buildings.

Although components are corrosion resistant, extinguishers installed where they may be subject to aggressive environments (such as marine) shall be protected from possible deterioration as required by AS2444 and NZS4503.

10. SERVICING

10.1 INSPECTION AND MAINTENANCE

Periodic inspection and testing of these extinguishers should be carried out in accordance with the Australian Standard AS1851. – Maintenance of Fire Protection Equipment. Section 15: Portable fire extinguishers, or New Zealand Standard NZS4503: The distribution, installation and maintenance of hand operated fire fighting equipment for use in buildings as appropriate for the country where installed.

10.2 SAFETY PRECAUTIONS

- a) Before attempting any repairs, ensure that all propellant gas has been expelled from the extinguisher. Completely depressurise it by inverting the extinguisher and squeezing the operating lever.
- b) Safety glasses and gloves should be worn as eye and skin irritation may occur upon frequent or prolonged contact with the dry powder. Dust masks should also be worn as the dry powder may cause sneezing or slight irritation of the nose and throat.
- c) Do not mix different types or different brands of dry powders. This can result in a pressure increase within a cylinder, creating a hazardous situation.

10.3 RECHARGING INSTRUCTION

Recharging of this extinguisher requires no special tools. However, the repair of detail parts is impractical and all defective parts should be replaced with new parts, which are issued in kit form. To act as a guide to servicing agents, details of replacement kits are shown in the drawing at the back of this Technical Data Sheet.

The recharging of these extinguishers should be carried out as per the “after use routine” AS1851. Section 15 or NZS4503 as applicable.

Additionally, the following steps should also be followed:

Note: Before commencing, check the date of the last pressure test, which will have been recorded on the maintenance record tag.
If pressure testing is required, it must be carried out before any recharging of the extinguisher takes place.
Refer to AS1851. Section 15 or NZS4503 for pressure test requirements as applicable.

Proceed as follows:

- i) Observe the Safety Precautions as listed in 10.2, paying particular attention to ensure all nitrogen gas pressure has been released.
- ii) Remove hose assembly from the extinguisher valve assembly.
Remove valve assembly from the extinguisher body.
Unscrew slowly, if there is any residual pressure, an audible sound will be noticeably heard.
The valve should not be further removed until sound ceases.

PRODUCT: 9.0kg ABE DRY POWDER FIRE EXTINGUISHER

PAGE: 8 of 11

MODEL No's: R9.0ABE

ISSUE: A 00

DATE: 07/16/15

- iii) Empty and discard all residual dry powder from the cylinder.

Note: **NEVER** re-use old powder.

- iv) Unscrew siphon tube from valve assembly.

- v) Remove the spring and valve check stem assembly from the valve body. Clean the spring and internals of the valve body with compressed air ensuring all deposits of dry powder are removed.
Replace check stem assembly if 'O' ring seals are damaged.

- vi) Remove the neck seal 'O' ring from the valve and discard. Replace with new 'O' ring. Clean 'O' ring groove and mount new 'O' ring into its seating making sure it is not twisted.
Lubricate 'O' ring lightly with petroleum jelly.

- vii) Lightly lubricate the check stem 'O' ring with petroleum jelly (using sparingly) and avoid getting any on the check stem seating.
Return check stem assembly and spring to the valve.

- viii) Clean the siphon tube with soft cloth and blow compressed air through to ensure clear passage and all powder deposits are removed.
Screw the siphon tube back into the valve assembly until siphon tube shoulders at the end of its thread, hand tight.

- ix) Visually inspect the interior of the cylinder for any corrosion or foreign materials. If the cylinder is corroded, condemn and replace extinguisher. If foreign materials are present, thoroughly clean and dry the cylinder before refilling.

- x) Fill with 9.0kg Presto Super ABE powder as stated on the label.
Use only '**Presto Super ABE**' powder. The weight of the dry powder is critical. Over or under filling may render the extinguisher ineffective.

- xi) Clean the dry powder from the neck threads with a stiff bristle brush. A toothbrush will suffice to do this job. Make sure 'O' ring seat in top of neck ring is clean and free from any powder.

Note: The next operation must be performed immediately after filling to avoid the powder from packing down which makes it difficult to insert the siphon tube into the powder.

- xii) Screw the valve assembly into the cylinder by centering the siphon tube carefully in the middle of the neck ring opening. Push down into the powder, making sure the valve thread is lined up with the neck ring threads. Screw the valve assembly home into the cylinder until the shoulder on the valve body is compressing the 'O' ring seal hard onto its seat in the top of the neck ring.

Note: The valve should not be tightened by excessive force. A firm hand tightening will be sufficient.

xiii) **Pressurise the extinguisher with nitrogen and a small amount of helium**

The extinguisher will require a charging adaptor that fits into the valve outlet.

SAFETY PRECAUTION

Ensure that the pressurising equipment used fully complies with the Apparatus Safety Requirements of AS3676 Section 5.

Procedure

- a) Fit the charging adaptor to the valve outlet.
- b) Connect the pressurising line to charging adaptor quick connect and set the system pressure regulator to a maximum of 150kPa above the extinguisher working pressure.
- c) Open the system pressure control valve, depress extinguisher operating lever, and charge extinguisher to the correct working pressure of 1500kPa. The pressure to be taken from the pressurising line gauge and not the extinguisher gauge.

Note: Check the extinguisher gauge pointer is in the green operating range. If not replace the gauge. The extinguisher will require depressurising before removing gauge. Follow relevant instructions in Section 10.2 and 10.3.

- d) Upon reaching the extinguisher working pressure, release extinguisher operating lever to close valve. Turn off system gas supply.
- e) Engage safety pin. Disconnect supply line from the charging adaptor and remove the adaptor from the valve outlet.
- f) Check the extinguisher for leaks as described in 10.4.

10.4 **TEST FOR LEAKS**

After pressurising, the extinguisher must be tested for leaks.

Proceed as follows:

- i) Put the fire extinguisher in the Helium leakage test station.
- ii) Start up the device to make Helium leakage test.

PRODUCT: 9.0kg ABE DRY POWDER FIRE EXTINGUISHER

PAGE: 10 of 11

MODEL No's: R9.0ABE

ISSUE: A 00

DATE: 07/16/15

Note: If the device shows red light, take off the fire extinguisher and put it into the water to check the leaking position. Then rectify by replacing valve stem components, pressure gauge or 'O' rings as required. Follow instructions as per recharge 10.3.

- iii) If the device shows green light, that means there is no leakage.
- iv) Pass anti-tamper sealing tie through safety pin, around handle and lever, thread, and pull tight.
- v) Each extinguisher shall have a maintenance / service label fitted.

TROUBLE SHOOTING GUIDE

WARNING: Determine the source of the leak before the extinguisher is depressurised.
Follow section 10.2 for safety precautions and section 10.3 for devalving and recharging.

<u>PROBLEM</u>	<u>CORRECTIVE ACTION</u>
Leak at neck ring 'O' ring.	Remove valve assembly, remove and discard 'O' ring, clean seating in neck ring. Clean 'O' ring groove on valve and install new 'O' ring. Lubricate 'O' ring with petroleum jelly. Remount valve assembly.
Leak at valve outlet.	Remove valve and disassemble to remove check stem. Clean all components, making sure all sealing surfaces are clean. Examine valve check stem assembly. Replace if any components damaged. Reassemble extinguisher.
Leak from gauge threads.	Remove gauge, clean threads, apply Loctite 569 thread sealant and re-install.
Defective gauge (ie. Leak through gauge)	Remove gauge and replace with new one (seal threads with Loctite 569).

PRODUCT: 9.0kg ABE DRY POWDER FIRE EXTINGUISHER

PAGE: 11 of 11

MODEL No's: R9.0ABE (RH30266A)

ISSUE: A 00

DATE: 07/16/15

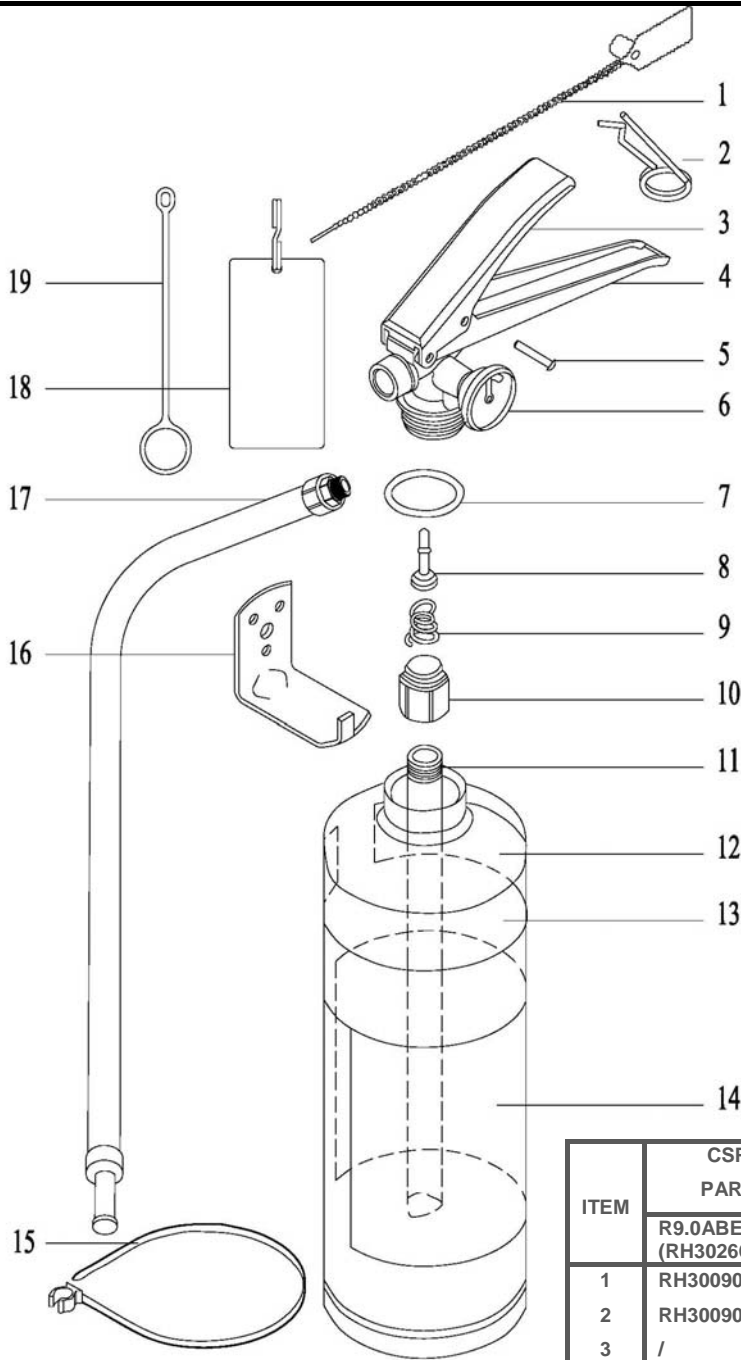

ITEM	CSP PART	DESCRIPTION	QTY
		R9.0ABE (RH30266A)	9.0 kg ABE DRY POWDER FIRE EXT
1	RH300909	INDICATOR SEAL (WHITE)	1
2	RH300908	9.0 kg SAFETY PIN (SUS201)	1
3	/	LEVER (SUS304)	1
4	/	HANDLE (SUS304)	1
5	/	RIVET (SUS304)	1
6	RH300512	PRESSURE GAUGE 1500 kPa	1
7	T300101-9	NECK SEAL O-RING	1
8	/	9.0 kg VALVE STEM	1
9	/	9.0 kg VALVE SPRING (SUS304H)	1
10	/	9.0 kg SIPHON TUBE ADAPTOR	1
11	RH300301	9.0 kg SIPHON TUBE-457mm	1
12	RH500258	9.0 kg CYLINDER ASSEMBLY	1
13	/	IDENTIFICATION BAND	1
14	RH30266A-T	9.0 kg LABEL ABE DRY POWDER	1
15	RH300603	HOSE CLIP AND CABLE TIE INEGRATED	1
16	RH300731	9.0 kg BRACKET (Q235)	1
17	RH500416A	9.0 kg HOSE ASSEMBLY	1
18	RH501311	HANGTAG	1
19	RH300910	SEAL (GREEN)	1