

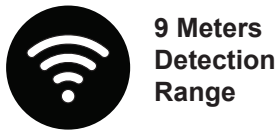

Smart Racking Sensor Light

Specifications	
SKU	RACKSENLT
Components	Smart Racking Sensor Light Users Manual x 1 D Batteries x 6
Colour	Yellow (case body) Black (top & base) Light: GREEN or RED
Size	Width 150.4mm Height 232mm Depth 105.5mm
Detection Range	9 Meters
Attachment Method	Magnetic, simply attached to corner of racking
Warranty	12 Months Warranty

12 MONTHS
WARRANTY



Description:

Make your warehouse a safe workplace by having these Smart Racking Sensor Light installed at corner of rackings. 9 meters detection range, light will turn red and horn will beep when it detects on-coming traffic from both sides to avoid possible collision.

Product Features

- Protects pedestrian and forklift drivers
- Avoids possible collision
- Easy installation, super strong magnets adhere to corner of metal racking
- Green light - when there is traffic on one side only, no horn beep
- Red light - when there is traffic approaching on both sides, horn beeps
- Horn beeps at 70 - 90 decibels, can be easily heard even in noisy warehouse environment
- Batteries can be easily replaced

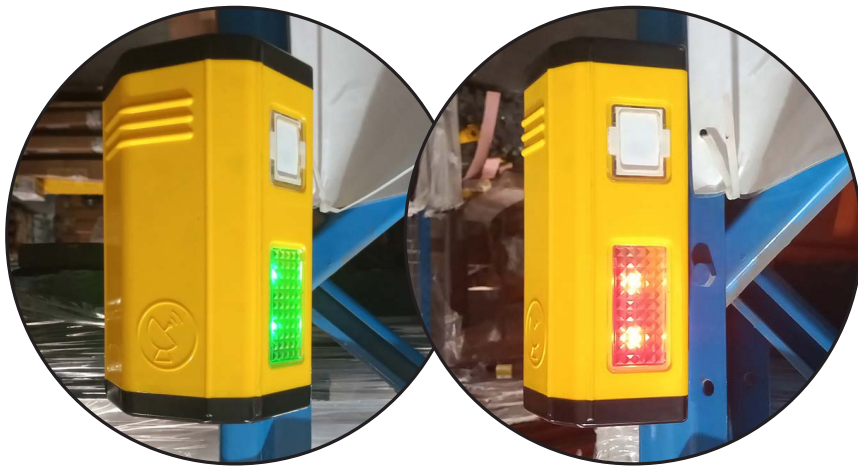

**Smart Racking
Sensor Light**

LED
Warning Light

GREEN:
Lights up when
detects on-coming
person or forklift
from one side

RED:
Lights up when
detects on-coming
traffic from both
sides, horn will beep

Recommended to attach
product at height taller than
forklift height to avoid forklift
accidentally hitting the product

Curved design, strong magnet,
attached to corner of racking.

Required 6 x D Batteries to
operate.

9 Meters
Detection
Range



Position unit
this way upwards

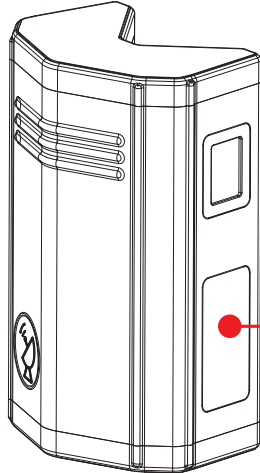

9 Meters
Detection
Range



Horn (70 - 90 Decibels) will
beep when sensor detect
traffic coming from either side



DO NOT immerse in water
Suitable for **INDOOR** use only
DO NOT hit product with forklift
DO NOT drop product from height
Unauthorised alteration / repair /
misuse / modification of parts may
result in non-functioning of product
and void product warranty



Smart Racking Sensor Light

Built-in Sensor
(induction probe)
9 Meters detection
range

LED
Warning Light

GREEN:
Lights up when
detects on-coming
person or forklift
from one side

RED:
Lights up when
detects on-coming
traffic from both
sides, horn will beep

Horn
(70 - 90 Decibels)

On/Off Switch
Unit will turn on
1 minute after
pressing swith

Curved design, adheres
to corner of racking, so
to detect on-coming
traffic from both sides

Strong Magnets, adjustable height
Can easily adhere to any racking or
metal surfaces.

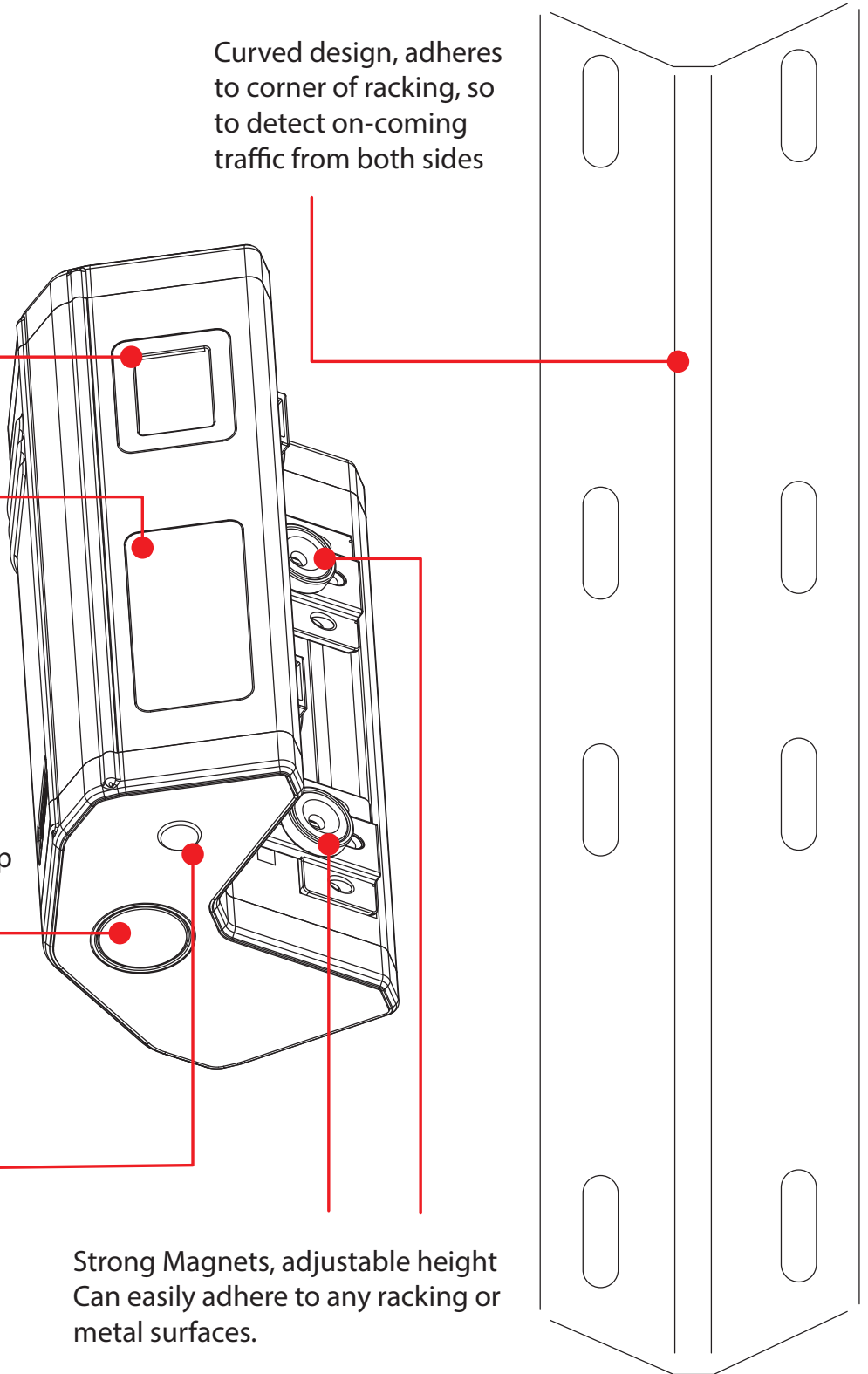

Racking Sensor Light

Batteries Replacement Guide

To Change Batteries

1. Open the top of casing
2. Untighten screws
3. Gently pull the cap off
4. Open the front cover to reveal batteries
5. Remove old batteries, replace with 6 x D Batteries
6. Repeat above steps in reverse
7. Make sure unit is closed properly before placing back on racking
8. Turn unit ON by pressing button at bottom of unit



DO NOT immerse in water
Suitable for **INDOOR** use only
DO NOT hit product with forklift
DO NOT drop product from height
Unauthorised alteration / repair /
misuse / modification of parts may
result in non-functioning of product
and void product warranty

